

R & PL SERIES

1.5—35 HORSEPOWER

RECIPROCATING AIR COMPRESSORS



PROVEN DESIGN.

PROVEN DEPENDABILITY.



**CHAMPION**<sup>®</sup>

A Gardner Denver Product

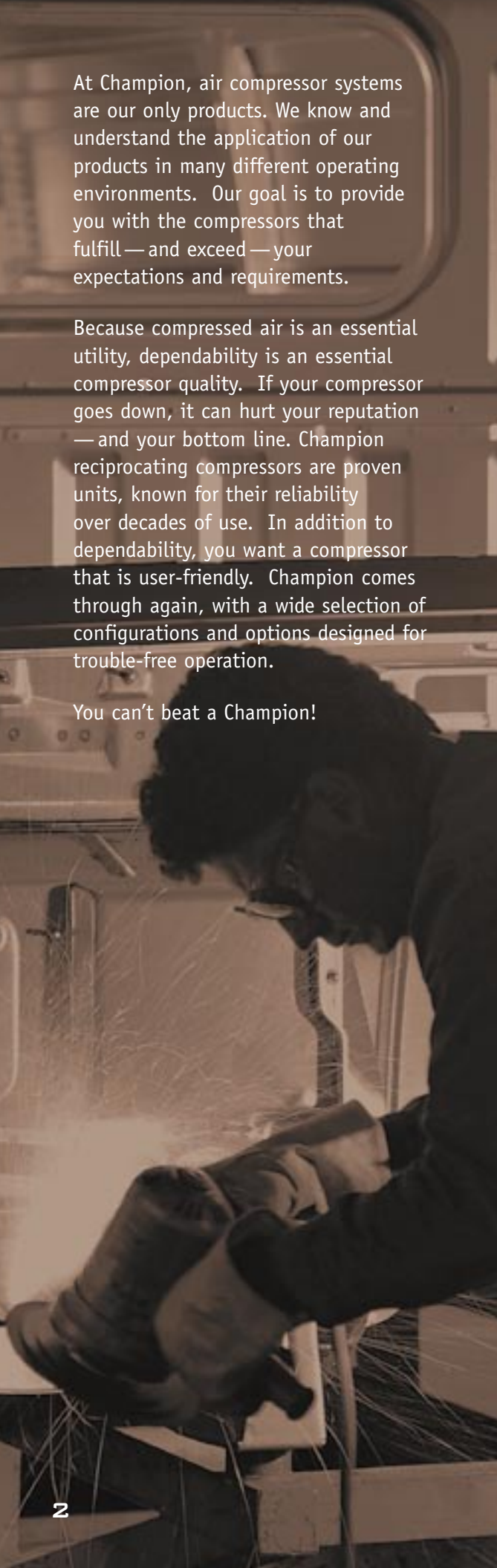

At Champion, air compressor systems are our only products. We know and understand the application of our products in many different operating environments. Our goal is to provide you with the compressors that fulfill — and exceed — your expectations and requirements.

Because compressed air is an essential utility, dependability is an essential compressor quality. If your compressor goes down, it can hurt your reputation — and your bottom line. Champion reciprocating compressors are proven units, known for their reliability over decades of use. In addition to dependability, you want a compressor that is user-friendly. Champion comes through again, with a wide selection of configurations and options designed for trouble-free operation.

You can't beat a Champion!

## CHAMPION RECIPROCATING COMPRESSORS...

### THE VALUE LEADERS.

#### PROVEN DESIGN.

Today's Champion Reciprocating Compressors are the product of decades of design and development. In fact, we introduced the first single-stage compressor in 1919 and have continuously improved its design through innovations in materials, production techniques and quality control.

#### PROVEN DEPENDABILITY.

You rely on compressed air to perform many tasks efficiently. Champion knows that reliability is one of the main reasons for a purchase. Our slow speed, built-in efficiency through design and the longest compressor warranty in the industry make Champion compressors the correct choice!

#### HIGH PERFORMANCE.

R- and PL-Series compressors are loaded with features designed for day-in, day-out performance. For example, Champion's unique automotive-type domed piston design allows the use of large diameter, low lift valves, while minimizing clearance volume for maximum air delivery.

#### LONG LIFE.

Features such as slow speed operation, rugged cast iron crankcase construction, corrosion resistant steel valves and tapered roller-type main bearings all contribute to long life.

#### USER-FRIENDLY DESIGN.

A wide selection of configurations and available options, coupled with serviceability features make it easy to operate and maintain a Champion compressor. Compare all the features on the pages that follow. You'll discover why Champion is the value leader in reciprocating compressors for a broad range of automotive and industrial applications.

# SELECT THE CONFIGURATION THAT MATCHES YOUR APPLICATION.

With many models from which to choose in both single-stage and two-stage, we can match your needs exactly. These configurations, combined with a wide choice of options, provide all the components for a customized installation. They are available in both R-Series splash-lubricated and PL-Series pressure-lubricated models.

## TWO-STAGE, TANK-MOUNTED AIR COMPRESSORS

Available with horizontal or space-saving vertical tanks. Two-stage air compressors compress air to a higher pressure than single stage compressors.



## TWO-STAGE, BASE-MOUNTED AIR COMPRESSORS

Designed for installations where air tanks are remotely located.



## TWO-STAGE, DUPLEX AIR COMPRESSORS

For extra air delivery when you need it without wasted space. Plus the flexibility of single operation, alternating between compressors, or duplex operation to meet high air demand.



## TWO-STAGE GASOLINE OR DIESEL ENGINE POWERED AIR COMPRESSORS

Truck and utility bed mounting design makes these compressors ideal for fleet and field service. Ideal for applications where electricity is not available.



## TWO-STAGE BARE COMPRESSOR PUMPS

For pump replacement or OEM applications, for the ultimate in air system design. Provides dependable service for industrial applications.



# THE SPLASH-LUBRICATED R-SERIES

Loaded with rugged features, the R-Series splash-lubricated compressors deliver high performance, long life and tremendous value.

## 1 MULTI-FINNED CYLINDERS

Cooler operating temperatures result in longer life and consistent performance over time.

## 2 INTEGRAL CYLINDER/HEAD

Gasketless design eliminates the possibility of blown head gaskets for trouble-free operation.

## 3 BALANCED PISTONS

Aluminum alloy first-stage piston is weight-matched to the cast iron second-stage piston, ensuring proper balance.

## 4 PISTON RINGS

Three compression rings and one oil control ring provide excellent oil control, and high efficiency air delivery.

## 5 LIGHTWEIGHT CONNECTING RODS

High-density, die-cast aluminum alloy rods minimize reciprocating weight. An integral, precision-bored crankpin bearing and a needle bearing for the piston pin properly distribute bearing loads for longer bearing life than bushings.

## 6 PRESSURE RELIEF VALVES

Located in interstage and discharge.

## 7 INTERCOOLERS

Large-diameter finned tubing is positioned to obtain the greatest cooling effect between stages for maximum compressor efficiency.

## 8 OPTIMIZED COOLING FAN/FLYWHEEL

Precision balanced flywheel has fan blades for optimum compressor cooling and life.

## 9 RELIABLE, HIGH-FLOW VALVES

Single-unit, disc-type valves provide low lift and long life. Discs are made of corrosion resistant

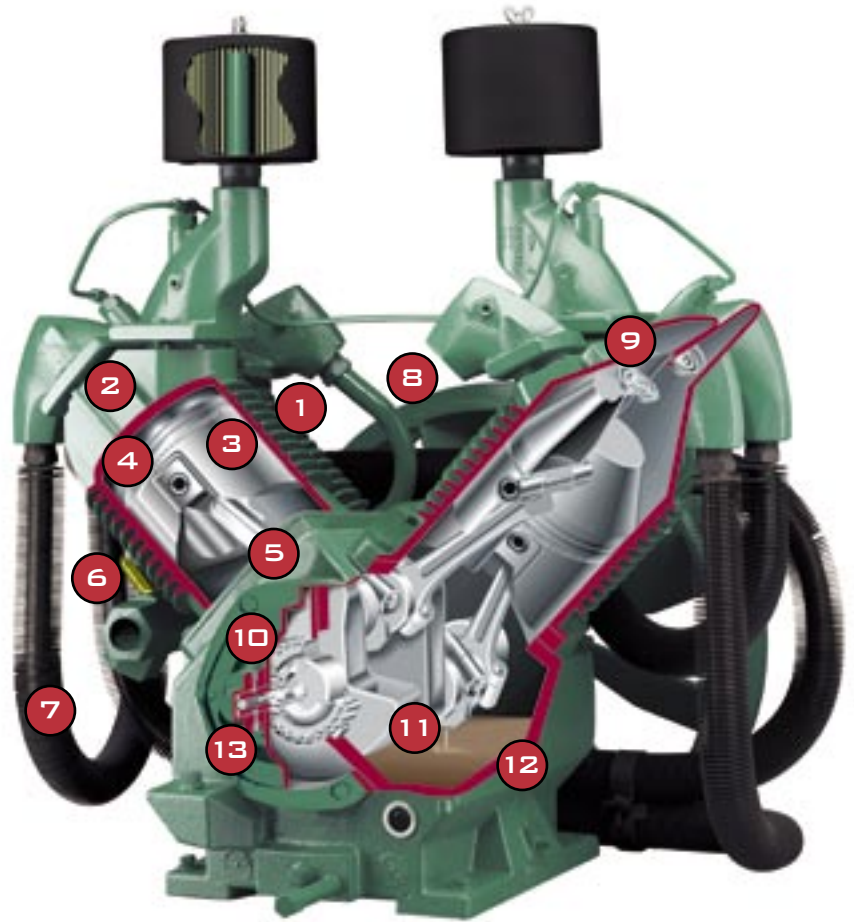

Swedish steel. Valves are easily serviced by removing the manifolds only.

## 10 OVERSIZED MAIN BEARINGS

Tapered roller-type main bearings deliver the longest possible life.

## 11 BALANCED CRANKSHAFT

Constructed of rugged ductile iron with large diameter throws for minimum bearing loads and counterweights to minimize vibration.

## 12 LARGE CAPACITY CRANKCASE

Rugged cast iron oil reservoir has convenient sight gauge glass, corner oil fill boss and large oil drain.

## 13 LOADLESS STARTING

Positive acting, governor-type centrifugal unloader assures longer motor life by allowing the compressor to start unloaded every time.

# THE PRESSURE-LUBRICATED PL-SERIES

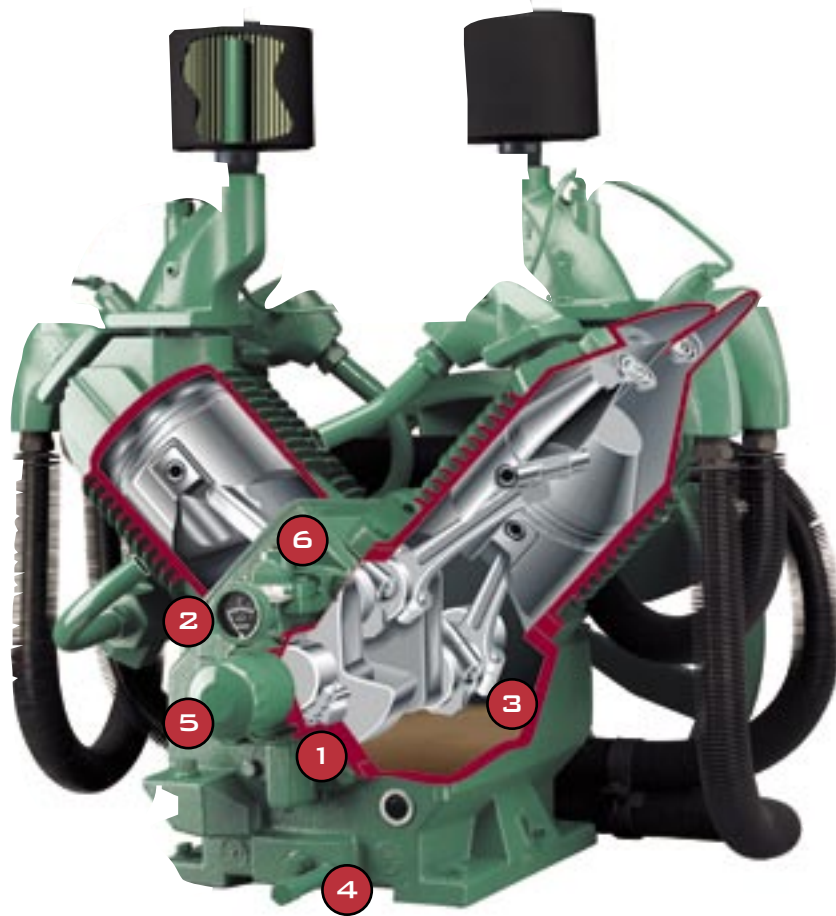

The PL-Series compressor has been designed to operate in extreme duty applications and is also an alternative to an R-Series unit. Because the PL-Series can operate up to 250 psi, in remote locations or in off-level operations, it is a true industrial use compressor. Champion is so confident in the way it has engineered and built its products, it offers a 5-year warranty on the compressor pump. The PL-Series features domed pistons, integral cylinder head, disc valves and an oil pump that provides lubricant to all crucial parts of the compressor. From its extra heavy duty design to its ease of maintenance, the Champion PL-Series exemplifies reliability, durability and quality.

## 1 PRESSURE LUBRICATION

Crankshaft and connecting rod bearings are pressure lubricated for extended life.

## 2 OIL PRESSURE GAUGE

Mounted on the front of the compressor for an excellent view and easy pressure monitoring.

## 3 BABBITT BEARINGS

Replaceable connecting rod crankshaft end bearings make repairs easy and inexpensive.

## 4 LUBRICANT FILTRATION

An external spin on oil filter and an internal oil inlet screen protect internal components from damaging debris.

## 5 POSITIVE DISPLACEMENT OIL PUMP

Provides lubricant to all critical areas of the compressor pump that require lubrication.

## 6 LOADLESS STARTING

Hydraulic unloader with-factory set pilot valve provides easy, loadless starts and low oil pressure protection for unattended operation.

# QUALITY ACCESSORIES AT A GLANCE

Many options are available to help you develop a Champion compressor package that exactly matches your specific operating requirements.

## 1 MAGNETIC STARTER

For thermal overload protection. Required for units 3 HP and up. May be mounted or unmounted.



1

## 2 AIR-COOLED OR WATER-COOLED AFTERCOOLER

Removes up to 65% of the moisture from discharged compressed air.

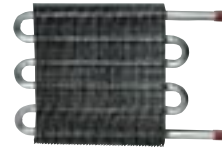

2

## 3 AUTOMATIC TANK DRAIN (PNEUMATIC)

Automatically removes water from air receiver upon demand. Eliminates the need for manual purging.



3

## 4 VIBRATION ISOLATORS

Isolates the compressor unit from the foundation or floor. Reduces noise and protects the unit from any out-of-level floor situation that could cause vibration and damage.

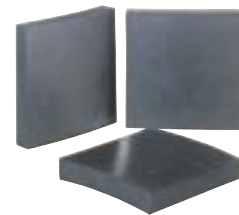

4

## 5 LOW OIL LEVEL MONITOR

Low Oil Level Monitor shuts down the unit when oil levels are below an adequate level. Prevents the unit from restarting if oil levels are not at an adequate level.



5

# QUALITY ACCESSORIES AT A GLANCE

## 6 REFRIGERATED AIR DRYER CYCLING OR NON-CYCLING

Cools compressed air to a 33°-39° dew point, eliminating additional downstream condensation in the air line. Normally, a dryer should be used in conjunction with an aftercooler.



6

## 7 DPR CONTROL PANEL

The Microprocessed Duplex Programmable Relay Panel was created for controlling a duplex air compressor package. The controller includes visual maintenance and shut down alarms.



7

## 8 CHAMPION COMPRESSOR LUBRICANTS

ChampLub lubricants are blended specifically for Champion compressors for use in harsh compressor environments. They are sourced from extremely stable base stocks and enhanced with carefully selected additive packages to provide long life and superior protection. ChampLub lubricants are suitable for a variety of applications and are available as a mineral oil, synthetic or food-grade synthetic.

Available in 55-gallon drums, five-gallon pails, one-gallon bottles and one-quart bottles.



8

## 9 DISC VALVES

Disc valves provide low lift and long life. Disc are made from Swedish Steel and are replaceable.



9

### OTHER OPTIONS

- Power Monitor shuts down unit in the event of single phasing, low voltage or phase reversal.
- Constant Speed Control prevents excessive motor start/stop cycles while saving energy.
- Dual Control allows compressor to run either in start/stop or constant speed mode.

# R & PL-SERIES BARE-PUMP DIMENSIONS

## R10D, R15B, PL-15

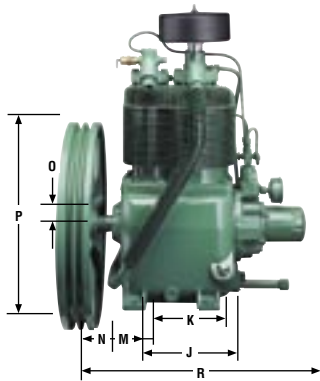
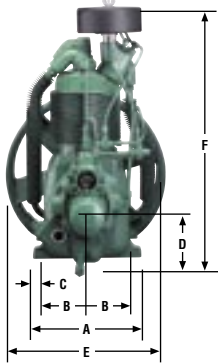

Item		R-10D R15B, PL-15 Inch	R-30D & PL-30 Inch	R-40A & PL-40 Inch	R-70A & PL-70 Inch
A	Base — Width	10	11¼	13	13
B	Boltdown — Width	4½	4¼	5¾	5¾
C	Boltdown to Edge	1	¾	¾	¾
D	Base to Crank CTR	5½	7	8	8¼
E	Overall Width	18	27	30	33
F	Overall Height	23¼	23¾	32	33¾
H	HP Exh. Opening Manifold	¾" Tubing	¾ NPT	1" Tubing	1¼ NPT
I	Boltdown Hole Dia.	½	¾	¾	¾
J	Base — Depth	7½	9¾	12	13¼
K	Boltdown — Depth	5¾	8¼	10	11¼
L	Boltdown to Edge	1	1	1	1
M	Bolt Hole to Wheel (Max.)	3	3¼	5¾	5¾
N	Flywheel — Width	2½	2¾	3½	3½
O	Crank Diameter	1	1¾	2¼	2¼
P	Flywheel Diameter	16½	19	22	22
Q	Flywheel	2VB	2VB	3VB	3VB
R	Overall Depth	20	22½	27½	28½
Approximate Shipping Weight (lbs.)		125	220	440	570

## R-30 & PL-30

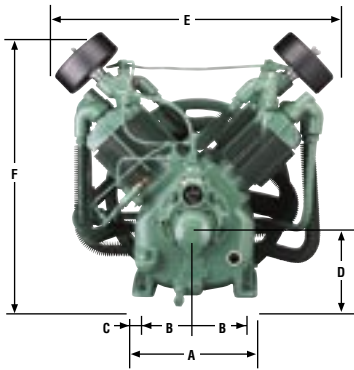

## R-40A & PL-40

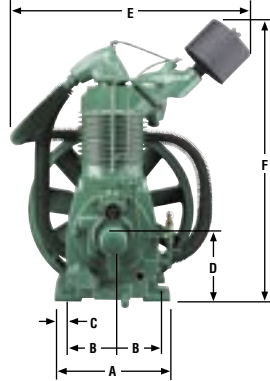

## R-70A & PL-70

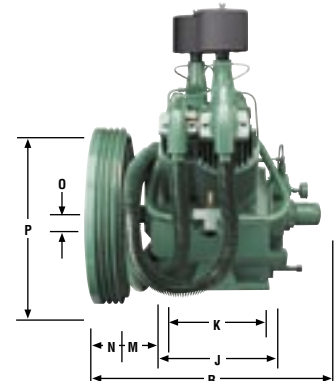
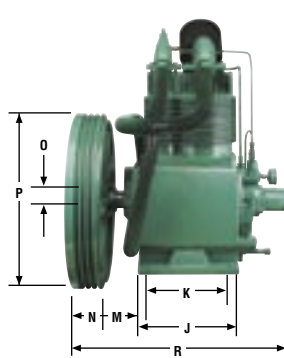
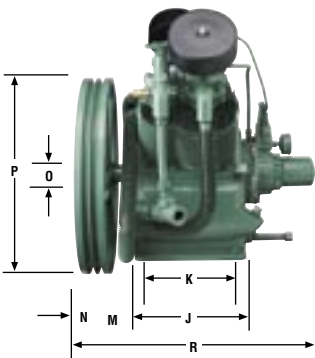
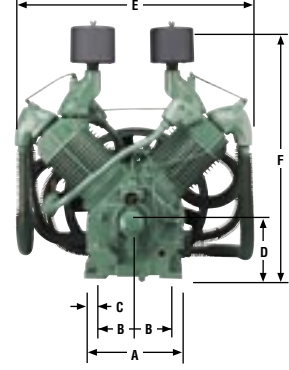

# SPECIFICATIONS

HORIZONTAL TANK MOUNTED UNITS – ELECTRIC DRIVEN								125 PSI Rating*			175 PSI Rating*			250 PSI Rating*		
Motor HP	Tank Cap Gal.	R-Series CASRSA	Pump Comp Model	PL-Series CBSPLA	Pump Comp Model	L x W x H Dimensions inches	Aprox. Ship Wt. lbs.	RPM	CFM Displ.	CFM Del'y	RPM	CFM Displ.	CFM Del'y	RPM	CFM Displ.	CFM Del'y
1½	30	HR1-3	R-10D	—	—	41½ x 21 x 44½	300	575	11.2	6.0	542	10.5	5.3	—	—	—
	60	HR1-6		51½ x 22¾ x 48¾		400										
	80	HR1-8		66½ x 22¾ x 48¾		425										
2	30	HR2-3		—		41½ x 21 x 44½	320	765	14.9	8.3	725	14.1	7.5	—	—	—
	60	HR2-6		51½ x 22¾ x 48¾		425										
	80	HR2-8		66½ x 22¾ x 48¾		455										
3	60	HR3-6	R-15B	HPL3-6	PL-15	51½ x 22¾ x 48¾	425	485	14.1	10.9	440	12.8	9.7	380	11.0	8.0
	80	HR3-8		HPL3-8		66½ x 22¾ x 48¾	485									
	120	HR3-12		HPL3-12		72½ x 24 x 55	725									
5	60	HR5-6		HPL5-6		51½ x 22¾ x 48¾	445	805	23.5	19.1	710	20.7	16.5	640	18.6	13.6
	80	HR5-8		HPL5-8		66½ x 22¾ x 48¾	535									
	120	HR5-12		HPL5-12		72½ x 24 x 55	765									
7½	80	HR7F-8	HPL7F-8	66½ x 22¾ x 48¾	570	990	28.7	23.1	990	28.7	23.1	870	25.5	18.2		
	120	HR7F-12	HPL7F-12	72½ x 24 x 55	800											
	80	HR7-8	HPL7-8	66½ x 22½ x 49¾	665										670	39.6
120	HR7-12	HPL7-12	72½ x 24 x 55¼	860												
10	80	HR10-8	HPL10-8	66½ x 22½ x 49¾	675	810	47.3	37.3	740	43.1	34.8	640	37.1	27.5		
	120	HR10-12	HPL10-12	72½ x 24 x 55¼	890											
	250	HR10-25	HPL10-25	87½ x 34¼ x 61½	1283											
15	80	HR15F-8	—	66½ x 22½ x 49¾	740	1045	60.9	50.2	1045	60.9	49.0	900	52.5	42.6		
	120	HR15F-12	HPL15F-12	72½ x 24 x 55¼	960											
	250	HR15F-25	HPL15F-25	88½ x 31 x 60½	1275											
	120	HRA15-12	HPL15-12	73½ x 27½ x 62½	1110										890	71.1
250	HRA15-25	HPL15-25	88½ x 31 x 68¾	1495												
20	120	HRA20-12	HPL20-12	73½ x 27½ x 64	1325	770	109.0	91.9	655	93.0	76.7	545	77.4	64.1		
	250	HRA20-25	HPL20-25	88½ x 31 x 70¼	1790											
25	120	HRA25-12	HPL25-12	73½ x 27½ x 64	1365	890	127.8	102.1	770	109.4	90.1	660	93.7	76.8		
	250	HRA25-25	HPL25-25	88½ x 31 x 70¼	1735											
30	120	HRA30-12	HPL30-12	73½ x 27½ x 64	1404	890	127.8	102.1	890	127.8	101.0	770	109.4	90.0		
	250	HRA30-25	HPL30-25	88½ x 31 x 70¼	1774											

VERTICAL TANK MOUNTED UNITS – ELECTRIC DRIVEN								125 PSI Rating*			175 PSI Rating*			250 PSI Rating*		
Motor HP	Tank Cap Gal.	R-Series CASRSA	Pump Comp Model	PL-Series CBSPLA	Pump Comp Model	L x W x H Dimensions inches	Aprox. Ship Wt. lbs.	RPM	CFM Displ.	CFM Del'y	RPM	CFM Displ.	CFM Del'y	RPM	CFM Displ.	CFM Del'y
1½	60	VR1-6	R-10D	—	—	32½ x 22½ x 76½	400	575	11.2	6.0	542	10.5	5.3	—	—	—
	80	VR1-8				32 x 24 x 77	425									
2	60	VR2-6				32½ x 22½ x 76½	425	765	14.9	8.3	725	14.1	7.5	—	—	—
	80	VR2-8				32 x 24 x 77	455									
3	60	VR3-6	R-15B	VPL3-6	PL-15	32½ x 22½ x 76½	425	485	14.1	10.9	440	12.8	9.7	380	11.0	8.0
	80	VR3-8		VPL3-8		32 x 24 x 77	485									
	120	VR3-12		VPL3-12		42½ x 30 x 80½	725									
5	60	VR5-6		VPL5-6		32½ x 22½ x 76½	455	805	23.5	19.1	710	20.7	16.5	640	18.6	13.6
	80	VR5-8		VPL5-8		33 x 24 x 77	535									
	120	VR5-12		VPL5-12		42½ x 30 x 82	765									
7½	80	VR7F-8	VPL7F-8	33 x 24 x 77	570	990	28.7	23.1	990	28.7	23.1	870	25.5	18.2		
	120	VR7F-12	VPL7F-12	42½ x 30 x 82	800											
	80	VR7-8	VPL7-8	42½ x 30 x 82	665										670	39.6
120	VR7-12	VPL7-12	46 3/8 x 30 x 82	800												
10	80	VR10-8	VPL10-8	42½ x 30 x 66 3/4	860	810	48.5	37.3	740	43.1	34.8	640	37.1	27.5		
	120	VR10-12	VPL10-12	46 3/8 x 30 x 80 3/4	890											
15	120	VR15F-12	—	46 3/8 x 30 x 80 3/4	890	1045	63.5	50.2	1045	63.5	49.0	900	52.5	42.6		

Note: Pressure Lubricated units are capable of 250 PSIG operation \*Units tested in accordance with CAGI/PNEUROP Acceptance Test Code PN2CPTC2.

# SPECIFICATIONS

BASE MOUNTED UNITS – ELECTRIC DRIVEN															
Motor HP	R-Series CABRSA	Pump Comp Model	PL-Series CBBPLA	Pump Comp Model	L x W x H Dimensions inches	Aprox. Ship Wt. lbs.	125 PSI Rating*			175 PSI Rating*			250 PSI Rating*		
							RPM	CFM Displ.	CFM Del'y	RPM	CFM Displ.	CFM Del'y	RPM	CFM Displ.	CFM Del'y
1½	BR-1	R-10D	—	—	29½ x 21 x 29¼	205	575	11.2	6.0	542	10.5	5.3	—	—	—
2	BR-2		—	—		205	765	14.9	8.3	725	14.1	7.5	—	—	—
3	BR-3	R-15B	BPL-3	PL-15	30½ x 21 x 29¼	230	485	14.1	10.9	440	12.8	9.7	380	11.0	8.0
5	BR-5		BPL-5			280	805	23.5	19.1	710	20.7	16.5	640	18.6	13.6
7½	BRF-7		BPL-7F			310	990	28.7	23.9	990	28.7	23.1	870	25.5	18.2
	BR-7	R-30D	BPL-7	PL-30	42¾ x 22¼ x 28¾	430	670	39.6	30.0	575	33.5	25.8	520	30.2	21.3
10	BR-10		BPL-10			540	810	48.5	37.3	740	43.1	34.8	640	37.1	27.5
	BRF-15	R-40A	BPL-15F	PL-40	49½ x 26¼ x 38	550	1045	63.5	50.2	1045	63.5	49.0	900	52.5	42.6
15	BRA-15		BPL-15			730	890	71.1	59.0	770	61.5	53.7	700	55.9	45.8
20	BRA-20	R-70A	BPL-20	PL-70	53 x 27½ x 39½	1000	770	109.0	91.9	655	93.0	76.7	545	77.4	64.1
25	BRA-25		BPL-25			1020	890	127.8	102.1	770	109.4	90.1	660	93.7	76.8
30	BRA-30		BPL-30			1059	890	127.8	102.1	890	127.0	101.1	770	109.4	90.0

TANK MOUNTED DUPLEX UNITS – ELECTRIC DRIVEN																
Motor HP	Tank Cap Gal.	R-Series CADRSA	Pump Comp Model	PL-Series CBDPLA	Pump Comp Model	L x W x H Dimensions inches	Aprox. Ship Wt. lbs.	125 PSI Rating*			175 PSI Rating*			250 PSI Rating*		
								RPM	CFM Displ.	CFM Del'y	RPM	CFM Displ.	CFM Del'y	RPM	CFM Displ.	CFM Del'y
2 (2)	80	HR2D-8	R10D	—	—	67½ x 28½ x 50½	715	765	29.8	16.6	725	28.2	15.0	—	—	—
	120	HR2D-12				91¾ x 26½ x 48¾	940	765	29.8	16.6	725	28.2	15.0	—	—	—
3 (2)	80	HR3D-8	R-15B	HPL30-8	PL-15	67½ x 28½ x 50¼	725	485	28.2	21.8	440	25.6	19.4	380	22.0	16.0
	120	HR3D-12		HPL30-12		91¾ x 26½ x 48¾	950	485	28.2	21.8	440	25.6	19.4	380	22.0	16.0
5 (2)	80	HR5D-8		HPL5D-8		67½ x 28½ x 50¼	755	805	47.0	38.2	710	41.4	33.0	640	37.2	27.2
	120	HR5D-12		HPL5D-12		91¾ x 26½ x 48¾	980	805	47.0	38.2	710	41.4	33.0	640	37.2	27.2
7½ (2)	250	HR7DF-12	HPL7D-12	91¾ x 26½ x 50¼	1305	670	79.2	60.0	575	67.0	51.6	520	60.4	42.6		
		HR7DF-25	HPL7DF-25	87½ x 32 x 64	1485	990	57.4	47.8	990	57.4	47.8	870	51.0	36.4		
		HR7DF-25	HPL7DF-25			1675	670	79.2	60.0	575	67.0	51.6	520	60.4	42.6	
10 (2)		HR10D-25	R-30D	HPL10D-25	PL-30	87½ x 32 x 64	1725	810	97.0	74.6	740	86.2	69.6	640	74.2	55.0
		HR15DF-25		HPL15DF-25			1860	1045	127.0	100.4	1045	127.0	98.0	900	105.0	85.2
15 (2)		HRA15D-25	R-40A	HPL15D-25	PL-40	88½ x 55 x 73½	2460	890	142.2	118.0	770	123.0	107.4	700	111.8	91.6
20 (2)		HRA20D-25	R-70A	HPL20D-25	PL-70	88½ x 62 x 74¾	2845	770	218.0	183.8	655	186.0	153.4	545	154.8	128.2
25 (2)		HRA25D-25		HPL25D-25			2940	890	255.6	204.2	770	218.8	180.2	660	187.4	153.6
30 (2)		HR30D-25		HPL30D-25			3018	890	255.6	204.2	890	255.6	202.0	770	218.8	180.0

Note: Pressure Lubricated units are capable of 250 PSIG operation \*Units tested in accordance with CAGI/PNEURO P Acceptance Test Code PN2CPTC2.

# SPECIFICATIONS

TANK MOUNTED UNITS – ENGINE DRIVEN														
Motor HP	Tank Cap Gal.	R-Series CAERSA	Pump Comp Model	PL-Series CBEPLA	Pump Comp Model	L x W x H Dimensions inches	Splash Aprox. Ship Wt. lbs.	Pressure Aprox. Ship Wt. lbs.	175 PSI Rating*			250 PSI Rating*		
									RPM	CFM Displ.	CFM Del'y	RPM	CFM Displ.	CFM Del'y
8	30	HGR3-3	R-15B	HGPL3-3	PL-15	38 x 22¾ x 45	345	345	600	17.9	14.3	—	—	—
***11	30	HGR5-3		HGPL5-3		38 x 22¾ x 45½	409	450	895	26.1	20.1	650	18.9	13.6
	8	HGR5-LP		HGPL5-LP		40 x 21¾ x 34¾	404	445						
	—	BGR5		BGPL5		36½ x 21 x 28¾	279	320						
	60	HGR5-6H		HGPL5-6H		32½ x 21 x 48	475	514						
	80	HGR5-8		HGPL5-8		66½ x 21 x 51	514	555						
12½	30	HGR6-3		HGPL6-3		38 x 22¾ x 45½	399	440	1025	29.9	23.2	950	27.7	19.8
	60	HGR6-6K		HPL6-6H		32½ x 21 x 48	475	514						
	80	HGR6-8		HGPL6-8		66½ x 21 x 51	514	555						
	—	BGR6		BGPL-6		40 x 21 x 29¼	279	279						
20	80	HGR10-8	R-30D	HGPL10-8	PL-30	66½ x 21 x 49¾	715	715	765	44.6	34.4	680	39.6	29.5
23	5	BGR-12		BGPL-12		46 x 28 x 35¾	645	645	940	55.0	39.5	810	489	38.0
27	4 (2)	BDRA-15	R-40A	BDPL-15	PL-40	52 x 29 x 42	813	813	910	72.8	59.0	800	64.0	51.5
35	5	BGRA-15		BGPLA-15		63 x 41 x 49	1075	1075						
*9	30	HDR5-3	R-15B	HDPL-15	PL-15	38 x 32 x 46	500	500	710	20.7	16.5	650	18.9	13.6
	—	BDR5		BDPL-5		38¾ x 21 x 29¾	493	493						
	60	HDR5-6		HDPL5-6		32 x 22 x 49	518	518						

NOTE: Pressure lubricated units are capable of 250 PSIG operation. 12.5 HP and larger packages do not come equipped with a fuel tank.

\*Diesel Driven \*\*Units tested in accordance with CAGI/PNEURO P Acceptance Test Code PN2CPTC3. \*\*\*Honda Engine

BARE PUMPS															
Motor HP	R-Series CAPRSA	PL-Series CBPPLA	Displ./Rev cubic feet	125 PSI Rating*		175 PSI Rating*		250 PSI Rating*		Bore inches dia.	Stroke inches	Number cylinders	Oil Capacity quarts	Aprox. Ship Weight pounds	
				RPM	CFM Del'y	RPM	CFM Del'y	RPM	CFM Del'y						
1½	R-10D	—	.01942	575	6.0	542	5.3	—	—	4⅝ & 2½	2	2	2	125	
2				765	8.3	725	7.5	—	—						
3	R-15B	PL-15A	.02916	497	11.8	440	9.7	380	8.0		3	4	4	220	
5				805	19.1	710	16.5	640	13.6						
7½				990	23.9	990	28.7	870	18.2						
10	R-30D	PL-30A	.05828	670	30.0	575	25.8	520	21.3		4	4	4	440	
15				810	37.3	740	34.8	640	27.5						
20	R-40A	PL-40A	.0800	1045	50.2	1045	49.0	900	42.6		6¼ & 3¼	4½	2	4	440
25				890	59.0	770	53.7	700	45.8						
30				770	91.9	655	76.7	545	64.1						
25	R-70A	PL-70A	.1420	890	102.1	770	90.1	660	76.8	4	4	6½	570		
30				890	102.1	890	101.0	770	90.0						

Note: Pressure Lubricated units are capable of 250 PSIG operation \*Units tested in accordance with CAGI/PNEURO P Acceptance Test Code PN2CPTC2.

# THE CHAMPION ASSEMBLED UNIT WARRANTIES

## COMPRESSOR PUMP WARRANTY

Each new Champion Assembled Unit has a five (5) year warranty on the compressor pump only, against defects in materials or workmanship under normal use and service, from the date of installation or sixty-six (66) months from the date of shipment by Champion or a Champion distributor, whichever may occur first.

The five-year extended warranty covers parts and labor and is prorated over the five years as follows:

Year One — 100% coverage  
Year Two — 90% coverage  
Year Three — 80% coverage  
Year Four — 70% coverage  
Year Five — 60% coverage

*Head valves are warranted for Year One only.* Champion makes no warranty on components and/or accessories furnished to Champion by third parties, such as electric motors, gasoline engines and controls. These are warranted only to the extent of the original manufacturer's warranty to Champion. Electric motors must be equipped with thermal overload protection to have warranty consideration. The extended five-year warranty will apply to ASME air receivers if they are installed on rubber vibro isolator pads or approved equivalent.

## 5 YEAR ELECTRIC MOTOR

Any Champion package purchased after January 1, 2003 built with a Baldor or Toshiba electric motor are warranted for 60 months from start-up or 63 months from shipment. Other manufacturer's motors furnished due to customer request or special requirements carry the motor manufacturer's warranty.

## PACKAGE WARRANTY

Champion warrants each new air compressor package to be free from defects in material and workmanship under normal use and service for a period of one year (12 months) from the date of installation or 15 months from the date of shipment by Champion.

## LIMITED WARRANTY

Warranty shall not apply to any equipment which has been subjected to misuse, neglect or accident, nor shall it apply to any equipment that has been repaired or altered by any person(s) not authorized by Champion. Failure caused by lack of proper maintenance is not covered by warranty. In no event shall Champion be liable for consequential damages or contingent liabilities arising out of failure of any compressor or part to operate properly. When a compressor pump or component is changed or replaced during the warranty period, the new/replaced item(s) is warranted for only the remainder of the original warranty period. Complete warranty details are included in compressor operating manual.

## U.L. STANDARDS

Champion, in common with other major, industrial compressor manufacturers, does not market compressors which are U.L. listed. In general, U.L. is concerned with electrical components that may be utilized on compressor units, rather than a complete compressor package or system. All electrical components used on Champion compressors are U.L. listed. Each component – motor, starter, pressure switch, control panel – carries a U.L. identification mark on the nameplate or inside the electrical enclosure cover. The mark will be the letters "UR" reversed (as if held up to a mirror), indicating the item is "recognized" by U.L. On tankmounted units, the air receiver tank and tank pressure relief valve are ASME Code. The tank carries a National Board Registration number which appears on a stamped, metal plate welded to the tank.

**CHAMPION**<sup>®</sup>  
A Gardner Denver Product

1301 North Euclid Avenue  
Princeton, Illinois 61356 USA  
Phone 888/436-5499  
Fax 815/872-0421  
E-mail: [Champion@championpneumatic.com](mailto:Champion@championpneumatic.com)  
[www.championpneumatic.com](http://www.championpneumatic.com)



Member of

